

# TRAFFIC CRASH REPORT

\*DENOTES MANDATORY FIELD FOR SUPPLEMENT REPORT

LOCAL REPORT NUMBER\*

<input type="checkbox"/> PHOTOS TAKEN <input type="checkbox"/> SECONDARY CRASH <input type="checkbox"/> OH-2 <input type="checkbox"/> OH-1P <input type="checkbox"/> PRIVATE PROPERTY	<input type="checkbox"/> OH-3 <input type="checkbox"/> OTHER	LOCAL INFORMATION REPORTING AGENCY NAME* <b>City of Kent Police</b> NCIC* 0 6 7 0 3	2 0 2 2 - 0 0 0 1 0 9 5 4
---	---	---	---------------------------

COUNTY* 6 7	LOCALITY* 1	LOCATION: CITY, VILLAGE, TOWNSHIP* <b>Kent</b>	CRASH DATE / TIME* 0 7 0 1 2 0 2 2 / 1 8 5 9	CRASH SEVERITY 5
----------------	----------------	---	---	---------------------

ROUTE TYPE	ROUTE NUMBER	PREFIX	N - NORTH S - SOUTH E - EAST W - WEST	LOCATION ROAD NAME <b>GOUGLER</b>	ROAD TYPE A V	LATITUDE DECIMAL DEGREES 4 1 1 1 5 4 7 1 7
------------	--------------	--------	--	--------------------------------------	------------------	---

ROUTE TYPE	ROUTE NUMBER	PREFIX	N - NORTH S - SOUTH E - EAST W - WEST	REFERENCE ROAD NAME (ROAD, MILEPOST, HOUSE #) <b>PARK</b>	ROAD TYPE A V	LONGITUDE DECIMAL DEGREES 8 1 1 3 6 0 2 2 3
------------	--------------	--------	--	--	------------------	--

REFERENCE POINT 1 - INTERSECTION 2 - MILE POST 3 - HOUSE # 1	DIRECTION FROM REFERENCE 2 N - NORTH S - SOUTH E - EAST W - WEST	ROUTE TYPE IR - INTERSTATE ROUTE(TP) US - FEDERAL US ROUTE SR - STATE ROUTE CR - NUMBERED COUNTY ROUTE TR - NUMBERED TOWNSHIP ROUTE	ROAD TYPE AL - ALLEY AV - AVENUE BL - BOULEVARD CR - CIRCLE CT - COURT DR - DRIVE HE - HEIGHTS	ROAD TYPE HW - HIGHWAY LA - LANE MP - MILEPOST OV - OVAL PK - PARKWAY PI - PIKE PL - PLACE	RD - ROAD SQ - SQUARE ST - STREET TE - TERRACE TL - TRAIL WA - WAY	INTERSECTION RELATED <input type="checkbox"/> WITHIN INTERSECTION OR ON APPROACH <input type="checkbox"/> WITHIN INTERCHANGE AREA ROADWAY <input type="checkbox"/> ROADWAY DIVIDED
--	---	--	---	---	---	--

DISTANCE FROM REFERENCE 3 0	DISTANCE UNIT OF MEASURE 2 1 - MILES 2 - FEET 3 - YARDS
--------------------------------	---

LOCATION OF FIRST HARMFUL EVENT 0 1 1 - ON ROADWAY 2 - ON SHOULDER 3 - IN MEDIAN 4 - ON ROADSIDE 5 - ON GORE 6 - OUTSIDE TRAFFIC WAY 7 - ON RAMP 8 - OFF RAMP	MANNER OF CRASH COLLISION/IMPACT 6 1 - NOT COLLISION BETWEEN TWO MOTOR VEHICLES IN TRANSPORT 2 - REAR-END 3 - HEAD-ON 4 - REAR-TO-REAR 5 - BACKING 6 - ANGLE 7 - SIDESWIPE, SAME DIRECTION 8 - SIDESWIPE, OPPOSITE DIRECTION 9 - OTHER / UNKNOWN	DIRECTION OF TRAVEL N - NORTH S - SOUTH E - EAST W - WEST	MEDIAN TYPE 1 - DIVIDED FLUSH MEDIAN (<4 FEET) 2 - DIVIDED FLUSH MEDIAN (≥4 FEET) 3 - DIVIDED, DEPRESSED MEDIAN 4 - DIVIDED, RAISED MEDIAN (ANY TYPE) 9 - OTHER/UNKNOWN
--	--	---	--

<input type="checkbox"/> WORK ZONE RELATED <input type="checkbox"/> WORKERS PRESENT <input type="checkbox"/> LAW ENFORCEMENT PRESENT <input type="checkbox"/> ACTIVE SCHOOL ZONE	WORK ZONE TYPE 1 - LANE CLOSURE 2 - LANE SHIFT/CROSSOVER 3 - WORK ON SHOULDER OR MEDIAN 4 - INTERMITTENT OR MOVING WORK 5 - OTHER	LOCATION OF CRASH IN WORK ZONE 1 - BEFORE THE 1ST WORK ZONE WARNING SIGN 2 - ADVANCE WARNING AREA 3 - TRANSITION AREA 4 - ACTIVITY AREA 5 - TERMINATION AREA	CONTOUR 1	CONDITIONS 1	SURFACE 2
---	--	---	--------------	-----------------	--------------

LIGHT CONDITION 1 1 - DAYLIGHT 2 - DAWN/DUSK 3 - DARK - LIGHTED ROADWAY 4 - DARK - ROADWAY NOT LIGHTED 5 - DARK - UNKNOWN ROADWAY LIGHTING 9 - OTHER / UNKNOWN	WEATHER 0 2 1 - CLEAR 2 - CLOUDY 3 - FOG, SMOG, SMOKE 4 - RAIN 5 - SLEET, HAIL 6 - SNOW 7 - SEVERE CROSSWINDS 8 - BLOWING SAND, SOIL, DIRT, SNOW 9 - FREEZING RAIN OR FREEZING DRIZZLE 99 - OTHER / UNKNOWN	1 - STRAIGHT LEVEL 2 - STRAIGHT GRADE 3 - CURVE LEVEL 4 - CURVE GRADE 9 - OTHER/UNKNOWN 1 - DRY 2 - WET 3 - SNOW 4 - ICE 5 - SAND, MUD, DIRT, OIL, GRAVEL 6 - WATER (STANDING, MOVING) 7 - SLUSH 9 - OTHER/UNKNOWN 1 - CONCRETE 2 - BLACKTOP, BITUMINOUS, ASPHALT 3 - BRICK/BLOCK 4 - SLAG, GRAVEL, STONE 5 - DIRT 9 - OTHER/UNKNOWN
---	--	--

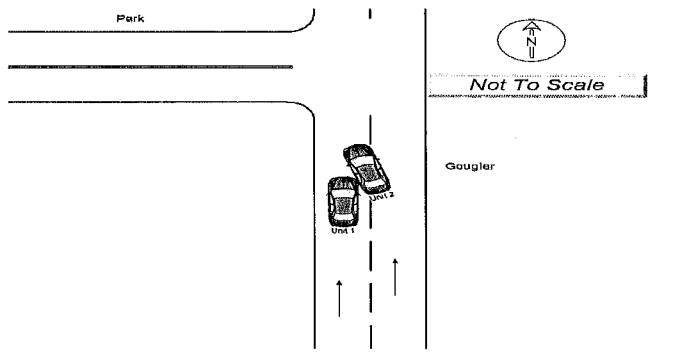
NARRATIVE <b>Unit #1 was northbound on Gougler in the left lane.</b> <b>Unit #2 was northbound on Gougler in the right lane.</b> <b>Unit #2 attempted to change lanes in front of Unit #1 and struck Unit #1.</b>	 <p>Indicate the north direction with an "N" on the compass diagram.</p>  <p>Not To Scale</p>
--	--

CRASH REPORTED DATE / TIME 0 7 0 1 2 0 2 2 / 1 8 5 9	DISPATCH DATE / TIME 0 7 0 1 2 0 2 2 / 1 8 5 9	ARRIVAL DATE / TIME 0 7 0 1 2 0 2 2 / 1 9 0 5	SCENE CLEARED DATE / TIME 0 7 0 1 2 0 2 2 / 1 9 3 0	REPORT TAKEN BY <input checked="" type="checkbox"/> POLICE AGENCY <input type="checkbox"/> MOTORIST <input type="checkbox"/> SUPPLEMENT (CORRECTION OR ADDITION TO AN EXISTING REPORT SENT TO COPS)
TOTAL TIME ROADWAY CLOSED 0 0 0	OTHER INVESTIGATION TIME 0 3 0	TOTAL MINUTES 0 6 1	OFFICER'S NAME* <b>Carnahan, Michael</b>	CHECKED BY OFFICER'S NAME* <b>Bowen, Jared</b>
			OFFICER'S BADGE NUMBER* 2 4 7	CHECKED BY OFFICER'S BADGE NUMBER* 2 1 4

**OWNER**

UNIT # 01 OWNER NAME: LAST, FIRST, MIDDLE (X) SAME AS DRIVER  
 THORNTON, GABRIEL, ALLEN

OWNED PHONE: HOME LINE AREA CODE (X) SAME AS DRIVER  
 COMMERCIAL CARRIER PHONE: INCLUDE AREA CODE

OWNER ADDRESS: STREET, CITY, STATE, ZIP (X) SAME AS DRIVER  
 365 MAIN ST 17, Munroe Falls, OH 44262

COMMERCIAL CARRIER: NAME, ADDRESS, CITY, STATE, ZIP

**DAMAGE**

DAMAGE SCALE

2 1 - NONE 3 - FUNCTIONAL DAMAGE  
 2 - MINOR DAMAGE 4 - DISABLING DAMAGE  
 9 - UNKNOWN

**VEHICLE**

LP STATE OH LICENSE PLATE # JNR5449 VEHICLE IDENTIFICATION # 1N4AL3AP2HC284580 VEHICLE YEAR 2017 VEHICLE MAKE Nissan

INSURANCE VERIFIED INSURANCE COMPANY COMMONWEALTH INSURANCE POLICY # OHA2210QC03630 COLOR GRY VEHICLE MODEL ALTIMA

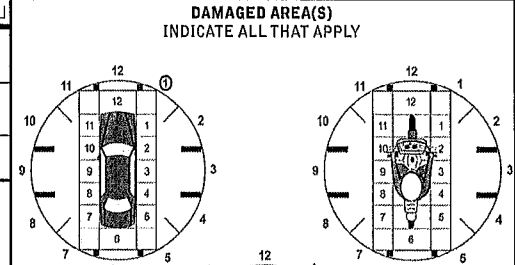

TYPE OF USE:  COMMERCIAL  GOVERNMENT  IN EMERGENCY RESPONSE

US DOT # \_\_\_\_\_ TOWED BY: COMPANY NAME \_\_\_\_\_

HAZARDOUS MATERIAL:  MATERIAL CLASS # \_\_\_\_\_  PLACARD ID # \_\_\_\_\_

UNIT TYPE: 01

# OF TRAILING UNITS: 00

1 - PASSENGER CAR 7 - MOTORCYCLE 2-WHEELED 12 - GOLF CART 18 - LIMO (LIVERY VEHICLE) 23 - PEDESTRIAN / SKATER  
 2 - PASSENGER VAN (MINIVAN) 8 - MOTORCYCLE 3-WHEELED 13 - SNOWMOBILE 19 - BUS (16+ PASSENGERS) 24 - WHEELCHAIR (ANY TYPE)  
 3 - SPORT UTILITY VEHICLE 9 - AUTOCYCLE 14 - SINGLE UNIT TRUCK 20 - OTHER VEHICLE 25 - OTHER NON-MOTORIST  
 4 - PICK UP 10 - MOPED OR MOTORIZED BICYCLE 15 - SEMI-TRACTOR 21 - HEAVY EQUIPMENT 26 - BICYCLE  
 5 - CARGO VAN 11 - ALL TERRAIN VEHICLE (ATV / UTV) 16 - FARM EQUIPMENT 22 - ANIMAL WITH RIDER OR ANIMAL-DRAWN VEHICLE 27 - TRAIN  
 6 - VAN (9-15 SEATS) 17 - MOTORHOME 99 - UNKNOWN OR HITSKIP

WAS VEHICLE OPERATING IN AUTONOMOUS MODE WHEN CRASH OCCURRED? 2

1 - YES 2 - NO 9 - OTHER / UNKNOWN

AUTONOMOUS MODE LEVEL: 0

0 - NO AUTOMATION 3 - CONDITIONAL AUTOMATION 9 - UNKNOWN  
 1 - DRIVER ASSISTANCE 4 - HIGH AUTOMATION  
 2 - PARTIAL AUTOMATION 5 - FULL AUTOMATION

SPECIAL FUNCTION: 01

1 - NONE 6 - BUS - CHARTER/TOUR 11 - FIRE 16 - FARM 21 - MAIL CARRIER  
 2 - TAXI 7 - BUS - INTERCITY 12 - MILITARY 17 - MOWING 99 - OTHER / UNKNOWN  
 3 - ELECTRONIC RIDE SHARING 8 - BUS - SHUTTLE 13 - POLICE 18 - SNOW REMOVAL  
 4 - SCHOOL TRANSPORT 9 - BUS - OTHER 14 - PUBLIC UTILITY 19 - TOWING  
 5 - BUS - TRANSIT/COMMUTER 10 - AMBULANCE 15 - CONSTRUCTION EQUIPMENT 20 - SAFETY SERVICE PATROL

CARGO BODY TYPE: 01

1 - NO CARGO BODY TYPE / NOT APPLICABLE 3 - VEHICLE TOWING ANOTHER MOTOR VEHICLE 5 - INTERMODAL CONTAINER CHASSIS 8 - POLE 12 - CONCRETE MIXER  
 2 - BUS 4 - LOGGING 6 - CARGO VAN/ENCLOSED BOX 9 - CARGO TANK 13 - AUTO TRANSPORTER  
 7 - GRAIN/CHIPS/GRAVEL 11 - DUMP 10 - FLAT BED 14 - GARBAGE/REFUSE 99 - OTHER / UNKNOWN

VEHICLE DEFECTS: 01

1 - TURN SIGNALS 4 - BRAKES 7 - WORN OR SLICK TIRES 9 - MOTOR TROUBLE 99 - OTHER / UNKNOWN  
 2 - HEAD LAMPS 5 - STEERING 8 - TRAILER EQUIPMENT DEFECTIVE 10 - DISABLED FROM PRIOR ACCIDENT  
 3 - TAIL LAMPS 6 - TIRE BLOWOUT

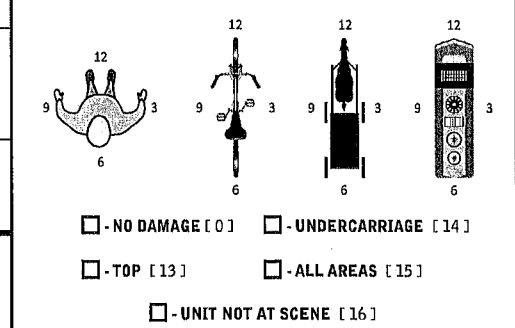
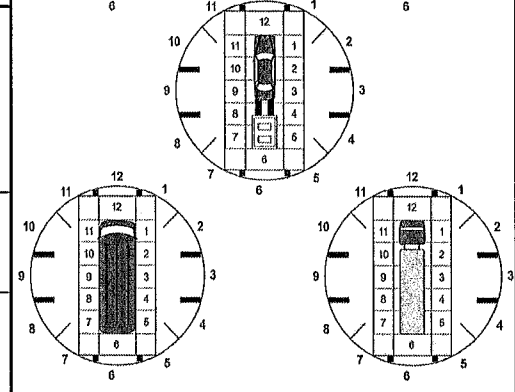

NON-MOTORIST LOCATION AT IMPACT: 01

1 - INTERSECTION - MARKED CROSSWALK 3 - INTERSECTION - OTHER 6 - BICYCLE LANE 9 - MEDIAN/CROSSING ISLAND 12 - FIRST RESPONDER AT INCIDENT SCENE  
 2 - INTERSECTION - UNMARKED CROSSWALK 4 - MIDDLEBLOCK - MARKED CROSSWALK 7 - SHOULDER / ROADSIDE 10 - DRIVEWAY ACCESS 14 - ENTERING OR CROSSING SPECIFIED LOCATION  
 5 - TRAVEL LANE - OTHER LOCATION 8 - SIDEWALK 11 - SHARED USE PATHS OR TRAILS 15 - WALKING, RUNNING, JOGGING, PLAYING 16 - WORKING  
 9 - OTHER / UNKNOWN

ACTION: 4

1 - NON-CONTACT 1 - STRAIGHT AHEAD 7 - MAKING U-TURN 13 - NEGOTIATING A CURVE OR LEAVING TRAFFIC LANE 18 - APPROACHING OR LEAVING VEHICLE  
 2 - NON-COLLISION 2 - BACKING 8 - ENTERING TRAFFIC LANE 14 - ENTERING OR CROSSING SPECIFIED LOCATION 19 - STANDING  
 3 - STRIKING 3 - CHANGING LANES 9 - LEAVING TRAFFIC LANE 15 - WALKING, RUNNING, JOGGING, PLAYING 20 - OTHER NON-MOTORIST  
 4 - STRUCK PRE-CRASH ACTIONS 4 - OVERTAKING/PASSING 10 - PARKED 16 - WORKING 21 - STANDING OUTSIDE DISABLED VEHICLE  
 5 - BOTH STRIKING & STRUCK 5 - MAKING RIGHT TURN 11 - SLOWING OR STOPPED IN TRAFFIC 17 - PUSHING VEHICLE 99 - OTHER / UNKNOWN  
 6 - MAKING LEFT TURN 12 - DRIVERLESS 17 - PUSHING VEHICLE 99 - OTHER / UNKNOWN  
 9 - OTHER / UNKNOWN

INITIAL POINT OF CONTACT: 01

0 - NO DAMAGE 14 - UNDERCARRIAGE  
 1-12 - REFER TO UNIT DIAGRAM 15 - VEHICLE NOT AT SCENE  
 13 - TOP 99 - UNKNOWN

CONTRIBUTING CIRCUMSTANCES: 01

1 - NONE 7 - LEFT OF CENTER 13 - IMPROPER START FROM A PARKED POSITION 17 - VISION OBSTRUCTION 21 - LYING IN ROADWAY  
 2 - FAILURE TO YIELD 8 - FOLLOWING TOO CLOSE / ACDA 14 - STOPPED OR PARKED ILLEGALLY 18 - OPERATING DEFECTIVE EQUIPMENT 22 - NOT DISCERNIBLE  
 3 - RAN RED LIGHT 9 - IMPROPER LANE CHANGE 15 - SWERVING TO AVOID 19 - LOAD SHIFTING/FALLING/SPILLING 23 - OPENING DOOR INTO ROADWAY  
 4 - RAN STOP SIGN 10 - IMPROPER PASSING 16 - WRONG WAY 20 - IMPROPER CROSSING 99 - OTHER IMPROPER ACTION  
 5 - UNSAFE SPEED 11 - DROVE OFF ROAD 12 - IMPROPER BACKING

TRAFFIC: 1

TRAFFICWAY FLOW: 1 - ONE-WAY 2 - TWO-WAY

TRAFFIC CONTROL: 6

1 - ROUNDABOUT 4 - STOP SIGN  
 2 - SIGNAL 5 - YIELD SIGN  
 3 - FLASHER 6 - NO CONTROL

SEQUENCE OF EVENTS: 1

1 - OVERTURN/ROLLOVER 6 - EQUIPMENT FAILURE 11 - CROSS CENTERLINE - OPPOSITE DIRECTION OF TRAVEL 16 - RAILWAY VEHICLE 22 - WORK ZONE MAINTENANCE EQUIPMENT  
 2 - FIRE/EXPLOSION 7 - SEPARATION OF UNITS 12 - DOWNHILL RUNAWAY 17 - ANIMAL - FARM 23 - STRUCK BY FALLING, SHIFTING CARGO OR ANYTHING SET IN MOTION BY A MOTOR VEHICLE  
 3 - IMMERSION 8 - RAN OFF ROAD RIGHT 13 - OTHER NON-COLLISION 18 - ANIMAL - DEER 24 - OTHER MOVABLE OBJECT  
 4 - JACKKNIFE 9 - RAN OFF ROAD LEFT 14 - PEDESTRIAN 19 - ANIMAL - OTHER 20 - MOTOR VEHICLE IN TRANSPORT  
 5 - CARGO / EQUIPMENT LOSS OR SHIFT 10 - CROSS MEDIAN 15 - PEDALCYCLE 21 - PARKED MOTOR VEHICLE

# OF THROUGH LANES ON ROAD: 2

RAIL GRADE CROSSING: 1

1 - NOT INVOLVED  
 2 - INVOLVED-ACTIVE CROSSING  
 3 - INVOLVED-PASSIVE CROSSING

COLLISION WITH FIXED OBJECT - STRUCK

25 - IMPACT ATTENUATOR / CRASH CUSHION 31 - GUARDRAIL END 37 - TRAFFIC SIGN POST 43 - CURB 50 - WORK ZONE MAINTENANCE EQUIPMENT  
 26 - BRIDGE OVERHEAD STRUCTURE 32 - PORTABLE BARRIER 38 - OVERHEAD SIGN POST 44 - DITCH 51 - WALL  
 27 - BRIDGE PIER OR ABUTMENT 33 - MEDIAN CABLE BARRIER 39 - LIGHT / LUMINARIES SUPPORT 45 - EMBANKMENT 52 - BUILDING  
 28 - BRIDGE PARAPET 34 - MEDIAN GUARDRAIL BARRIER 40 - UTILITY POLE 46 - FENCE 53 - TUNNEL  
 29 - BRIDGE RAIL 35 - MEDIAN CONCRETE BARRIER 41 - OTHER POST, POLE OR SUPPORT 47 - MAILBOX 54 - OTHER FIXED OBJECT  
 30 - GUARDRAIL FACE 36 - MEDIAN OTHER BARRIER 42 - CULVERT 48 - TREE 99 - OTHER / UNKNOWN  
 49 - FIRE HYDRANT

UNIT / NON-MOTORIST DIRECTION: FROM 2 TO 1

1 - NORTH 5 - NORTHEAST  
 2 - SOUTH 6 - NORTHWEST  
 3 - EAST 7 - SOUTHEAST  
 4 - WEST 8 - SOUTHWEST  
 9 - OTHER / UNKNOWN

UNIT SPEED: 020

POSTED SPEED: 25

DETECTED SPEED: 1

1 - STATED / ESTIMATED SPEED  
 2 - CALCULATED / EDR  
 3 - UNDETERMINED

**OWNER**

UNIT # 0 2 OWNER NAME: LAST, FIRST, MIDDLE ( ) SAME AS DRIVER  
 PETRIDIS, KATELYN, MICHELLE

OWNER ADDRESS: STREET, CITY, STATE, ZIP ( ) SAME AS DRIVER  
 5471 WAYLAND RD, Paris, OH 44266

COMMERCIAL CARRIER: NAME, ADDRESS, CITY, STATE, ZIP

OWNER PHONE: INCLUDE AREA CODE

COMMERCIAL CARRIER PHONE: INCLUDE AREA CODE

**DAMAGE**

DAMAGE SCALE

2 1 - NONE 3 - FUNCTIONAL DAMAGE  
 2 - MINOR DAMAGE 4 - DISABLING DAMAGE  
 9 - UNKNOWN

**VEHICLE**

LP STATE OH LICENSE PLATE # GYX5462 VEHICLE IDENTIFICATION # 1 9 X F C 2 F 5 4 G E 1 0 8 7 5 6 4 VEHICLE YEAR 2 0 1 6 VEHICLE MAKE Honda

INSURANCE VERIFIED INSURANCE COMPANY STATE FARM INSURANCE POLICY # 7820263A1935C COLOR COM VEHICLE MODEL CIVIC

COMMERCIAL  GOVERNMENT  IN EMERGENCY RESPONSE TYPE OF USE

INTERLOCK DEVICE EQUIPPED  HIT/SKIP UNIT #OCCUPANTS 0 2 US DOT #

VEHICLE WEIGHT GVWR/GCWR  
 1 - ≤10K LBS.  
 2 - 10,001 - 26K LBS.  
 3 - >26K LBS.

TOWED BY: COMPANY NAME

HAZARDOUS MATERIAL  
 MATERIAL RELEASED CLASS # PLACARD ID #  
 PLACARD

DAMAGED AREA(S) INDICATE ALL THAT APPLY

NO DAMAGE [ 0 ]  UNDERCARRIAGE [ 14 ]  
 TOP [ 13 ]  ALL AREAS [ 15 ]  
 UNIT NOT AT SCENE [ 16 ]

UNIT TYPE 0 1

1 - PASSENGER CAR 7 - MOTORCYCLE 2-WHEELED 12 - GOLF CART 18 - LIMO (LIVERY VEHICLE) 23 - PEDESTRIAN / SKATER  
 2 - PASSENGER VAN (MINIVAN) 8 - MOTORCYCLE 3-WHEELED 13 - SNOWMOBILE 19 - BUS (16+ PASSENGERS) 24 - WHEELCHAIR (ANY TYPE)  
 3 - SPORT UTILITY VEHICLE 9 - AUTOCYCLE 14 - SINGLE UNIT TRUCK 20 - OTHER VEHICLE 25 - OTHER NON-MOTORIST  
 4 - PICK UP 10 - MOPEL OR MOTORIZED BICYCLE 15 - SEMI-TRACTOR 21 - HEAVY EQUIPMENT 26 - BICYCLE  
 5 - CARGO VAN 11 - ALL TERRAIN VEHICLE (ATV / UTV) 16 - FARM EQUIPMENT 22 - ANIMAL WITH RIDER OR ANIMAL-DRAWN VEHICLE 27 - TRAIN  
 6 - VAN (9-15 SEATS) 17 - MOTORHOME 99 - UNKNOWN OR HITS/SKIP

# OF TRAILING UNITS 00

WAS VEHICLE OPERATING IN AUTONOMOUS MODE WHEN CRASH OCCURRED? 0

1 - YES 2 - NO 9 - OTHER / UNKNOWN 0 - NO AUTOMATION 3 - CONDITIONAL AUTOMATION 9 - UNKNOWN  
 1 - DRIVER ASSISTANCE 4 - HIGH AUTOMATION 5 - FULL AUTOMATION  
 2 - PARTIAL AUTOMATION

SPECIAL FUNCTION 0 1

1 - NONE 6 - BUS - CHARTER/TOUR 11 - FIRE 16 - FARM 21 - MAIL CARRIER  
 2 - TAXI 7 - BUS - INTERCITY 12 - MILITARY 17 - MOWING 99 - OTHER / UNKNOWN  
 3 - ELECTRONIC RIDE SHARING 8 - BUS - SHUTTLE 13 - POLICE 18 - SNOW REMOVAL  
 4 - SCHOOL TRANSPORT 9 - BUS - OTHER 14 - PUBLIC UTILITY 19 - TOWING  
 5 - BUS - TRANSIT/COMMUTER 10 - AMBULANCE 15 - CONSTRUCTION EQUIPMENT 20 - SAFETY SERVICE PATROL

CARGO BODY TYPE 0 1

1 - NO CARGO BODY TYPE / NOT APPLICABLE 3 - VEHICLE TOWING ANOTHER MOTOR VEHICLE 5 - INTERMODAL CONTAINER CHASSIS 8 - POLE 12 - CONCRETE MIXER  
 2 - BUS 4 - LOGGING 6 - CARGO VAN/ENCLOSED BOX 9 - CARGO TANK 13 - AUTO TRANSPORTER  
 7 - GRAIN/CHIPS/GRAVEL 11 - DUMP 10 - FLAT BED 14 - GARBAGE/REFUSE 99 - OTHER / UNKNOWN

VEHICLE DEFECTS

1 - TURN SIGNALS 4 - BRAKES 7 - WORN OR SLICK TIRES 9 - MOTOR TROUBLE 99 - OTHER / UNKNOWN  
 2 - HEAD LAMPS 5 - STEERING 8 - TRAILER EQUIPMENT DEFECTIVE 10 - DISABLED FROM PRIOR ACCIDENT  
 3 - TAIL LAMPS 6 - TIRE BLOWOUT

NON-MOTORIST LOCATION AT IMPACT

1 - INTERSECTION - MARKED CROSSWALK 3 - INTERSECTION - OTHER 6 - BICYCLE LANE 9 - MEDIAN/CROSSING ISLAND 12 - FIRST RESPONDER AT INCIDENT SCENE  
 2 - INTERSECTION - UNMARKED CROSSWALK 4 - MIDBLOCK - MARKED CROSSWALK 7 - SHOULDER / ROADSIDE 10 - DRIVEWAY ACCESS 99 - OTHER / UNKNOWN  
 5 - TRAVEL LANE - OTHER LOCATION 8 - SIDEWALK 11 - SHARED USE PATHS OR TRAILS

ACTION 3 PRE-CRASH ACTIONS 0 3

1 - NON-CONTACT 1 - STRAIGHT AHEAD 7 - MAKING U-TURN 13 - NEGOTIATING A CURVE OR LEAVING TRAFFIC LANE 18 - APPROACHING OR LEAVING VEHICLE  
 2 - NON-COLLISION 2 - BACKING 8 - ENTERING TRAFFIC LANE 14 - ENTERING OR CROSSING SPECIFIED LOCATION 19 - STANDING  
 3 - STRIKING 3 - CHANGING LANES 9 - LEAVING TRAFFIC LANE 15 - WALKING, RUNNING, JOGGING, PLAYING 20 - OTHER NON-MOTORIST  
 4 - STRUCK 4 - OVERTAKING/PASSING 10 - PARKED 16 - WORKING 21 - STANDING OUTSIDE DISABLED VEHICLE  
 5 - BOTH STRIKING & STRUCK 5 - MAKING RIGHT TURN 11 - SLOWING OR STOPPED IN TRAFFIC 17 - PUSHING VEHICLE 99 - OTHER / UNKNOWN  
 9 - OTHER / UNKNOWN 6 - MAKING LEFT TURN 12 - DRIVERLESS 99 - OTHER / UNKNOWN

INITIAL POINT OF CONTACT

0 8 0 - NO DAMAGE 14 - UNDERCARRIAGE  
 1-12 - REFER TO UNIT DIAGRAM 15 - VEHICLE NOT AT SCENE  
 13 - TOP 99 - UNKNOWN

CONTRIBUTING CIRCUMSTANCES 0 9

1 - NONE 7 - LEFT OF CENTER 13 - IMPROPER START FROM A PARKED POSITION 17 - VISION OBSTRUCTION 21 - LYING IN ROADWAY  
 2 - FAILURE TO YIELD 8 - FOLLOWING TOO CLOSE / ACDA 14 - STOPPED OR PARKED ILLEGALLY 18 - OPERATING DEFECTIVE EQUIPMENT 22 - NOT DISCERNIBLE  
 3 - RAN RED LIGHT 9 - IMPROPER LANE CHANGE 15 - SWERVING TO AVOID 19 - LOAD SHIFTING/FALLING/SPILLING 23 - OPENING DOOR INTO ROADWAY  
 4 - RAN STOP SIGN 10 - IMPROPER PASSING 16 - WRONG WAY 20 - IMPROPER CROSSING 99 - OTHER IMPROPER ACTION  
 5 - UNSAFE SPEED 11 - DROVE OFF ROAD 17 - VISION OBSTRUCTION 21 - LYING IN ROADWAY  
 6 - IMPROPER TURN 12 - IMPROPER BACKING

TRAFFIC

TRAFFICWAY FLOW 1 TRAFFIC CONTROL 6

1 - ONE-WAY 2 - TWO-WAY 1 - ROUNDABOUT 4 - STOP SIGN  
 2 - SIGNAL 5 - YIELD SIGN  
 3 - FLASHER 6 - NO CONTROL

SEQUENCE OF EVENTS

1 2 0 1 - OVERTURN/ROLLOVER 6 - EQUIPMENT FAILURE 11 - CROSS CENTERLINE - OPPOSITE DIRECTION OF TRAVEL 16 - RAILWAY VEHICLE 22 - WORK ZONE MAINTENANCE EQUIPMENT  
 2 - FIRE/EXPLOSION 7 - SEPARATION OF UNITS 12 - DOWNHILL RUNAWAY 17 - ANIMAL - FARM 23 - STRUCK BY FALLING, SHIFTING CARGO OR ANYTHING SET IN MOTION BY A MOTOR VEHICLE  
 3 - IMMERSION 8 - RAN OFF ROAD RIGHT 13 - OTHER NON-COLLISION 18 - ANIMAL - DEER 24 - OTHER MOVABLE OBJECT  
 4 - JACKKNIFE 9 - RAN OFF ROAD LEFT 14 - PEDESTRIAN 19 - ANIMAL - OTHER 20 - MOTOR VEHICLE IN TRANSPORT  
 5 - CARGO / EQUIPMENT LOSS OR SHIFT 10 - CROSS MEDIAN 15 - PEDALCYCLE 21 - PARKED MOTOR VEHICLE

COLLISION WITH FIXED OBJECT - STRUCK

25 - IMPACT ATTENUATOR / CRASH CUSHION 31 - GUARDRAIL END 37 - TRAFFIC SIGN POST 43 - CURB 50 - WORK ZONE MAINTENANCE EQUIPMENT  
 26 - BRIDGE OVERHEAD STRUCTURE 32 - PORTABLE BARRIER 38 - OVERHEAD SIGN POST 44 - DITCH 51 - WALL  
 27 - BRIDGE PIER OR ABUTMENT 33 - MEDIAN CABLE BARRIER 39 - LIGHT / LUMINARIES SUPPORT 45 - EMBANKMENT 52 - BUILDING  
 28 - BRIDGE PARAPET 34 - MEDIAN GUARDRAIL BARRIER 40 - UTILITY POLE 46 - FENCE 53 - TUNNEL  
 29 - BRIDGE RAIL 35 - MEDIAN CONCRETE BARRIER 41 - OTHER POST, POLE OR SUPPORT 47 - MAILBOX 54 - OTHER FIXED OBJECT  
 30 - GUARDRAIL FACE 36 - MEDIAN OTHER BARRIER 42 - CULVERT 48 - TREE 99 - OTHER / UNKNOWN  
 49 - FIRE HYDRANT

1 FIRST HARMFUL EVENT 1 MOST HARMFUL EVENT

# OF THROUGH LANES ON ROAD 2 RAIL GRADE CROSSING 1

1 - NOT INVOLVED  
 2 - INVOLVED-ACTIVE CROSSING  
 3 - INVOLVED-PASSIVE CROSSING

UNIT / NON-MOTORIST DIRECTION

FROM 2 TO 1

1 - NORTH 5 - NORTHEAST  
 2 - SOUTH 6 - NORTHWEST  
 3 - EAST 7 - SOUTHEAST  
 4 - WEST 8 - SOUTHWEST  
 9 - OTHER / UNKNOWN

UNIT SPEED 0 3 0 DETECTED SPEED 1

1 - STATED / ESTIMATED SPEED  
 2 - CALCULATED / EDR  
 3 - UNDETERMINED

POSTED SPEED 2 5



# MOTORIST / Non-MOTORIST

LOCAL REPORT NUMBER  
 2 0 2 2 - 0 0 0 1 0 9 5 4

<b>UNIT #</b> 0 1	<b>NAME: LAST, FIRST, MIDDLE</b> THORNTON, GABRIEL, ALLEN		<b>DATE OF BIRTH</b> 0 3 / 0 1 / 2 0 0 2		<b>AGE</b> 2 0	<b>GENDER</b> M				
<b>ADDRESS: STREET, CITY, STATE, ZIP</b> 365 N MAIN ST 17 ,Munroe Falls ,OH 44262				<b>CONTACT PHONE - INCLUDE AREA CODE</b>						
<b>INJURIES</b> 5	<b>INJURED TAKEN BY</b>	<b>EMS AGENCY (NAME)</b>	<b>INJURED TAKEN TO: MEDICAL FACILITY (NAME, CITY)</b>	<b>SAFETY EQUIPMENT USED</b> 0 4	<input type="checkbox"/> DOT-COMPLIANT MC HELMET	<b>SEATING POSITION</b> 0 1	<b>AIR BAG USAGE</b> 1	<b>EJECTION</b> 1	<b>TRAPPED</b> 1	
<b>OL STATE</b> O H	<b>OPERATOR LICENSE NUMBER</b>	<b>OFFENSE CHARGED</b>	<b>LOCAL CODE</b> <input type="checkbox"/>	<b>OFFENSE DESCRIPTION</b>		<b>CITATION NUMBER</b>				
<b>OL CLASS</b> 4	<b>ENDORSEMENT SELECT UP TO 2</b>	<b>RESTRICTION SELECT UP TO 3</b>	<b>DRIVER DISTRACTED BY</b> 1	<b>ALCOHOL / DRUG SUSPECTED</b> <input type="checkbox"/> ALCOHOL <input type="checkbox"/> MARIJUANA <input type="checkbox"/> OTHER DRUG		<b>CONDITION</b> 1	<b>ALCOHOL TEST</b> STATUS TYPE VALUE		<b>DRUG TEST(S)</b> STATUS TYPE RESULT SELECT UP TO 4	

<b>UNIT #</b> 0 2	<b>NAME: LAST, FIRST, MIDDLE</b> PETRIDIS, KATELYN, MICHELLE		<b>DATE OF BIRTH</b> 1 1 / 2 4 / 1 9 9 7		<b>AGE</b> 2 4	<b>GENDER</b> F				
<b>ADDRESS: STREET, CITY, STATE, ZIP</b> 5471 WAYLAND RD ,Paris ,OH 44266				<b>CONTACT PHONE - INCLUDE AREA CODE</b>						
<b>INJURIES</b> 5	<b>INJURED TAKEN BY</b>	<b>EMS AGENCY (NAME)</b>	<b>INJURED TAKEN TO: MEDICAL FACILITY (NAME, CITY)</b>	<b>SAFETY EQUIPMENT USED</b> 0 4	<input type="checkbox"/> DOT-COMPLIANT MC HELMET	<b>SEATING POSITION</b> 0 1	<b>AIR BAG USAGE</b> 1	<b>EJECTION</b> 1	<b>TRAPPED</b> 1	
<b>OL STATE</b> O H	<b>OPERATOR LICENSE NUMBER</b>	<b>OFFENSE CHARGED</b> 331.08	<b>LOCAL CODE</b> <input checked="" type="checkbox"/>	<b>OFFENSE DESCRIPTION</b> Driving in Marked La		<b>CITATION NUMBER</b> 23841				
<b>OL CLASS</b> 4	<b>ENDORSEMENT SELECT UP TO 2</b>	<b>RESTRICTION SELECT UP TO 3</b>	<b>DRIVER DISTRACTED BY</b> 1	<b>ALCOHOL / DRUG SUSPECTED</b> <input type="checkbox"/> ALCOHOL <input type="checkbox"/> MARIJUANA <input type="checkbox"/> OTHER DRUG		<b>CONDITION</b> 1	<b>ALCOHOL TEST</b> STATUS TYPE VALUE		<b>DRUG TEST(S)</b> STATUS TYPE RESULT SELECT UP TO 4	

<b>UNIT #</b>	<b>NAME: LAST, FIRST, MIDDLE</b>		<b>DATE OF BIRTH</b>		<b>AGE</b>	<b>GENDER</b>				
<b>ADDRESS: STREET, CITY, STATE, ZIP</b>				<b>CONTACT PHONE - INCLUDE AREA CODE</b>						
<b>INJURIES</b>	<b>INJURED TAKEN BY</b>	<b>EMS AGENCY (NAME)</b>	<b>INJURED TAKEN TO: MEDICAL FACILITY (NAME, CITY)</b>	<b>SAFETY EQUIPMENT USED</b>	<input type="checkbox"/> DOT-COMPLIANT MC HELMET	<b>SEATING POSITION</b>	<b>AIR BAG USAGE</b>	<b>EJECTION</b>	<b>TRAPPED</b>	
<b>OL STATE</b>	<b>OPERATOR LICENSE NUMBER</b>	<b>OFFENSE CHARGED</b>	<b>LOCAL CODE</b> <input type="checkbox"/>	<b>OFFENSE DESCRIPTION</b>		<b>CITATION NUMBER</b>				
<b>OL CLASS</b>	<b>ENDORSEMENT SELECT UP TO 2</b>	<b>RESTRICTION SELECT UP TO 3</b>	<b>DRIVER DISTRACTED BY</b>	<b>ALCOHOL / DRUG SUSPECTED</b> <input type="checkbox"/> ALCOHOL <input type="checkbox"/> MARIJUANA <input type="checkbox"/> OTHER DRUG		<b>CONDITION</b>	<b>ALCOHOL TEST</b> STATUS TYPE VALUE		<b>DRUG TEST(S)</b> STATUS TYPE RESULT SELECT UP TO 4	

INJURIES	SEATING POSITION	AIR BAG	OL CLASS	OL RESTRICTION(S)	DRIVER DISTRACTION	TEST STATUS
1 - FATAL 2 - SUSPECTED SERIOUS INJURY 3 - SUSPECTED MINOR INJURY 4 - POSSIBLE INJURY 5 - NO APPARENT INJURY	1 - FRONT - LEFT SIDE (MOTORCYCLE DRIVER) 2 - FRONT - MIDDLE 3 - FRONT - RIGHT SIDE 4 - SECOND - LEFT SIDE (MOTORCYCLE PASSENGER) 5 - SECOND - MIDDLE 6 - SECOND - RIGHT SIDE 7 - THIRD - LEFT SIDE (MOTORCYCLE SIDE CAR) 8 - THIRD - MIDDLE 9 - THIRD - RIGHT SIDE 10 - SLEEPER SECTION OF TRUCK CAB 11 - PASSENGER IN OTHER ENCLOSED CARGO AREA (NON-TRAILING UNIT, BUS, PICK-UP WITH CAP) 12 - PASSENGER IN UNENCLOSED CARGO AREA 13 - TRAILING UNIT 14 - RIDING ON VEHICLE EXTERIOR (NON-TRAILING UNIT) 15 - NON-MOTORIST 99 - OTHER / UNKNOWN	1 - NOT DEPLOYED 2 - DEPLOYED FRONT 3 - DEPLOYED SIDE 4 - DEPLOYED BOTH FRONT / SIDE 5 - NOT APPLICABLE 9 - DEPLOYMENT UNKNOWN	1 - CLASS A 2 - CLASS B 3 - CLASS C 4 - REGULAR CLASS (OHIO = D) 5 - MC MOPED ONLY 6 - NO VALID OL	1 - ALCOHOL INTERLOCK DEVICE 2 - COL INTRASTATE ONLY 3 - CORRECTIVE LENSES 4 - FARM WAIVER 5 - EXCEPT CLASS A BUS 6 - EXCEPT CLASS A & CLASS B BUS 7 - EXCEPT TRACTOR-TRAILER 8 - INTERMEDIATE LICENSE RESTRICTIONS 9 - LEARNER'S PERMIT RESTRICTIONS 10 - LIMITED TO DAYLIGHT ONLY 11 - LIMITED TO EMPLOYMENT 12 - LIMITED - OTHER 13 - MECHANICAL DEVICES (SPECIAL BRAKES, HAND CONTROLS, OR OTHER ADAPTIVE DEVICES) 14 - MILITARY VEHICLES ONLY 15 - MOTOR VEHICLES WITHOUT AIR BRAKES 16 - OUTSIDE MIRROR 17 - PROSTHETIC AID 18 - OTHER	1 - NOT DISTRACTED 2 - MANUALLY OPERATING AN ELECTRONIC COMMUNICATION DEVICE (TEXTING, TYPING, DIALING) 3 - TALKING ON HANDS-FREE COMMUNICATION DEVICE 4 - TALKING ON HAND-HELD COMMUNICATION DEVICE 5 - OTHER ACTIVITY WITH AN ELECTRONIC DEVICE 6 - PASSENGER 7 - OTHER DISTRACTION INSIDE THE VEHICLE 8 - OTHER DISTRACTION OUTSIDE THE VEHICLE 9 - OTHER / UNKNOWN	1 - NONE GIVEN 2 - TEST REFUSED 3 - TEST GIVEN, CONTAMINATED SAMPLE / UNUSABLE 4 - TEST GIVEN, RESULTS KNOWN 5 - TEST GIVEN, RESULTS UNKNOWN
<b>INJURED TAKEN BY</b> 1 - NOT TRANSPORTED / TREATED AT SCENE 2 - EMS 3 - POLICE 9 - OTHER / UNKNOWN	<b>EJECTION</b> 1 - NOT EJECTED 2 - PARTIALLY EJECTED 3 - TOTALLY EJECTED 4 - NOT APPLICABLE	<b>TRAPPED</b> 1 - NOT TRAPPED 2 - EXTRICATED BY MECHANICAL MEANS 3 - FREED BY NON-MECHANICAL MEANS	<b>OL ENDORSEMENT</b> H - HAZMAT M - MOTORCYCLE P - PASSENGER N - TANKER Q - MOTOR SCOOTER R - THREE-WHEEL MOTORCYCLE S - SCHOOL BUS T - DOUBLE & TRIPLE TRAILERS X - TANKER / HAZMAT	<b>CONDITION</b> 1 - APPARENTLY NORMAL 2 - PHYSICAL IMPAIRMENT 3 - EMOTIONAL (E.G., DEPRESSED, ANGRY, DISTURBED) 4 - ILLNESS 5 - FELL ASLEEP, FAINTED, FATIGUED, ETC. 6 - UNDER THE INFLUENCE OF MEDICATIONS / DRUGS / ALCOHOL 9 - OTHER / UNKNOWN	<b>ALCOHOL TEST TYPE</b> 1 - NONE 2 - BLOOD 3 - URINE 4 - BREATH 5 - OTHER	<b>DRUG TEST TYPE</b> 1 - NONE 2 - BLOOD 3 - URINE 4 - OTHER
<b>SAFETY EQUIPMENT</b> 1 - NONE USED 2 - SHOULDER BELT ONLY USED 3 - LAP BELT ONLY USED 4 - SHOULDER & LAP BELT USED 5 - CHILD RESTRAINT SYSTEM - FORWARD FACING 6 - CHILD RESTRAINT SYSTEM - REAR FACING 7 - BOOSTER SEAT 8 - HELMET USED 9 - PROTECTIVE PADS USED (ELBOW, KNEES, ETC.) 10 - REFLECTIVE CLOTHING 11 - LIGHTING - PEDESTRIAN / BICYCLE ONLY 99 - OTHER / UNKNOWN	<b>ALCOHOL TEST</b> STATUS TYPE VALUE	<b>DRUG TEST(S)</b> STATUS TYPE RESULT SELECT UP TO 4	<b>GENDER</b> F - FEMALE M - MALE U - OTHER / UNKNOWN	<b>DRUG TEST RESULT(S)</b> 1 - AMPHETAMINES 2 - BARBITURATES 3 - BENZODIAZEPINES 4 - CANNABINOIDS 5 - COCAINE 6 - OPIATES / OPIOIDS 7 - OTHER 8 - NEGATIVE RESULTS		



# OCCUPANT / WITNESS ADDENDUM

LOCAL REPORT NUMBER  
 2 0 2 2 - 0 0 0 1 0 9 5 4

**OCCUPANT**

UNIT # 01 NAME: LAST, FIRST, MIDDLE  
**CARLTON, BRYSON, MICHAEL**

ADDRESS: STREET, CITY, STATE, ZIP  
**1407 SUNSET WAY BLVD ,Kent ,OH 44240**

DATE OF BIRTH  
11 / 10 / 1999 AGE 22 GENDER M

CONTACT PHONE - INCLUDE AREA CODE

INJURIES 5 INJURED TAKEN BY      EMS AGENCY (NAME)      INJURED TAKEN TO: MEDICAL FACILITY (NAME, CITY)      SAFETY EQUIPMENT USED 04

DOT-COMPLIANT MC HELMET SEATING POSITION 06 AIR BAG USAGE 11 EJECTION 1 TRAPPED 1

**OCCUPANT**

UNIT # 01 NAME: LAST, FIRST, MIDDLE  
**HENRY, JACOB, R**

ADDRESS: STREET, CITY, STATE, ZIP  
**5708 POWDER MILL RD ,Franklin Twp ,OH 44240**

DATE OF BIRTH  
07 / 23 / 2000 AGE 21 GENDER M

CONTACT PHONE - INCLUDE AREA CODE

INJURIES 5 INJURED TAKEN BY      EMS AGENCY (NAME)      INJURED TAKEN TO: MEDICAL FACILITY (NAME, CITY)      SAFETY EQUIPMENT USED 04

DOT-COMPLIANT MC HELMET SEATING POSITION 03 AIR BAG USAGE 11 EJECTION 1 TRAPPED 1

**OCCUPANT**

UNIT # 02 NAME: LAST, FIRST, MIDDLE  
**PICONE, PAYTON, ALEXANDER**

ADDRESS: STREET, CITY, STATE, ZIP  
**1150 WEST PARKWAY BLVD ,Aurora ,OH 44202**

DATE OF BIRTH  
07 / 04 / 1997 AGE 24 GENDER M

CONTACT PHONE - INCLUDE AREA CODE

INJURIES 5 INJURED TAKEN BY      EMS AGENCY (NAME)      INJURED TAKEN TO: MEDICAL FACILITY (NAME, CITY)      SAFETY EQUIPMENT USED 04

DOT-COMPLIANT MC HELMET SEATING POSITION 03 AIR BAG USAGE 11 EJECTION 1 TRAPPED 1

**OCCUPANT**

UNIT #      NAME: LAST, FIRST, MIDDLE

ADDRESS: STREET, CITY, STATE, ZIP

DATE OF BIRTH

CONTACT PHONE - INCLUDE AREA CODE

INJURIES      INJURED TAKEN BY      EMS AGENCY (NAME)      INJURED TAKEN TO: MEDICAL FACILITY (NAME, CITY)      SAFETY EQUIPMENT USED     

DOT-COMPLIANT MC HELMET SEATING POSITION      AIR BAG USAGE      EJECTION      TRAPPED     

INJURIES	SAFETY EQUIPMENT USED	SEATING POSITION	AIR BAG USAGE
1 - FATAL	1 - NONE USED - VEHICLE OCCUPANT	1 - FRONT - LEFT SIDE (MOTORCYCLE DRIVER)	1 - NOT DEPLOYED
2 - SUSPECTED SERIOUS INJURY	2 - SHOULDER BELT ONLY USED	2 - FRONT - MIDDLE	2 - DEPLOYED FRONT
3 - SUSPECTED MINOR INJURY	3 - LAP BELT ONLY USED	3 - FRONT - RIGHT SIDE	3 - DEPLOYED SIDE
4 - POSSIBLE INJURY	4 - SHOULDER & LAP BELT USED	4 - SECOND - LEFT SIDE (MOTORCYCLE PASSENGER)	4 - DEPLOYED BOTH FRONT/SIDE
5 - NO APPARENT INJURY	5 - CHILD RESTRAINT SYSTEM - FORWARD FACING	5 - SECOND - MIDDLE	5 - NOT APPLICABLE
<b>INJURED TAKEN BY</b>		6 - SECOND - RIGHT SIDE	9 - DEPLOYMENT UNKNOWN
1 - NOT TRANSPORTED / TREATED AT SCENE	6 - CHILD RESTRAINT SYSTEM - REAR FACING	7 - THIRD - LEFT SIDE (MOTORCYCLE SIDE CAR)	<b>EJECTION</b>
2 - EMS	7 - BOOSTER SEAT	8 - THIRD - MIDDLE	1 - NOT EJECTED
3 - POLICE	8 - HELMET USED	9 - THIRD - RIGHT SIDE	2 - PARTIALLY EJECTED
9 - OTHER / UNKNOWN	9 - PROTECTIVE PADS USED (ELBOW, KNEES, ETC.)	10 - SLEEPER SECTION OF TRUCK CAB	3 - TOTALLY EJECTED
<b>GENDER</b>		11 - PASSENGER IN OTHER ENCLOSED CARGO AREA (NON-TRAILING UNIT, BUS, PICK-UP WITH CAP)	4 - NOT APPLICABLE
F - FEMALE	10 - REFLECTIVE CLOTHING	12 - PASSENGER IN UNENCLOSED CARGO AREA	<b>TRAPPED</b>
M - MALE	11 - LIGHTING - PEDESTRIAN / BICYCLE ONLY	13 - TRAILING UNIT	1 - NOT TRAPPED
U - OTHER / UNKNOWN	99 - OTHER / UNKNOWN	14 - RIDING ON VEHICLE EXTERIOR (NON-TRAILING UNIT)	2 - EXTRICATED BY MECHANICAL MEANS
		15 - NON-MOTORIST	3 - FREED BY NON-MECHANICAL MEANS
		99 - OTHER / UNKNOWN	

**WITNESS**

NAME: LAST, FIRST, MIDDLE

ADDRESS: STREET, CITY, STATE, ZIP

DATE OF BIRTH

CONTACT PHONE - INCLUDE AREA CODE

**WITNESS**

NAME: LAST, FIRST, MIDDLE

ADDRESS: STREET, CITY, STATE, ZIP

DATE OF BIRTH

CONTACT PHONE - INCLUDE AREA CODE

**WITNESS**

NAME: LAST, FIRST, MIDDLE

ADDRESS: STREET, CITY, STATE, ZIP

DATE OF BIRTH

CONTACT PHONE - INCLUDE AREA CODE



# Narrative Continuation

LOCAL REPORT NUMBER

2 0 2 2 - 0 0 0 1 0 9 5 4

[Empty narrative area]